

Triumph™

29 SERGER ACCESSORY/FEET KIT INSTRUCTIONS



Triumph™

You can further expand the Triumph's creative capabilities with these 29 feet. From working with lace and elastic, to stitching curves and creating perfectly straight hems, this foot kit allows you to make all of your sewing dreams a triumphant reality.

- Beading Foot
- Belt Loop Binder 3/4"
- Belt Loop Binder 1-1/2"
- Blindhem Foot
- Clear Foot
- Cording Foot 5mm
- Cover Chain Stitch Foot
- Curving Foot
- Double Fold Bias Binder 28mm
- Double Fold Bias Binder 36mm
- Elastic Foot
- Fabric Guide
- Knit/Woven Double Fold Bias Binder 8mm
- Knit/Woven Double Fold Bias Binder 10mm
- Knit/Woven Double Fold Bias Binder 15mm
- Lace Applicator Foot
- Open Toe Foot
- Pintuck Foot
- Piping/Cording Foot 5mm
- Plain Hemmer 1/4"
- Plain Hemmer 1/2"
- Quilt Guide
- Ruffling Foot
- Single Downturn Feller 1/4"
- Single Downturn Feller 5/8"
- Single Downturn Feller 1"
- Single Fold Bias Binder 28mm
- Single Fold Bias Binder 40mm
- Single Fold Bias Binder Knit/Woven 15mm
- Teflon Foot



FOR THE LOVE OF SEWING

www.babylock.com

Beading Foot

(BLE8-BF)

Instructions

Serge pearls, piping, cording, and more to the edge of fabric with ease and speed. This one-step foot will give all of your surface embellishments a professional finish.



MACHINE SETTINGS

Stitch type:	3-Thread Rolled Hem
Stitch selector:	D
Needle:	02
Stitch width:	M
Stitch length:	3-4 Rolled Hem
Upper knife:	Engaged "UNLOCKED"
Differential feed:	N-0.6
Sewing speed:	Slow to moderate speed

1. Remove the left needle from the machine. Set machine to narrow rolled hem (Refer to your instruction manual for details).
2. Replace the standard presser foot with the beading foot.
3. Set stitch length setting at 3-4 mm according to the size of beads used.
4. Position beads into beading foot as illustrated below.
5. Place edge of fabric you are attaching the beads to under the presser foot, lower presser foot, and stitch.

NOTE: It is recommended to sew a test sample before sewing your actual garment to determine the correct stitch length.

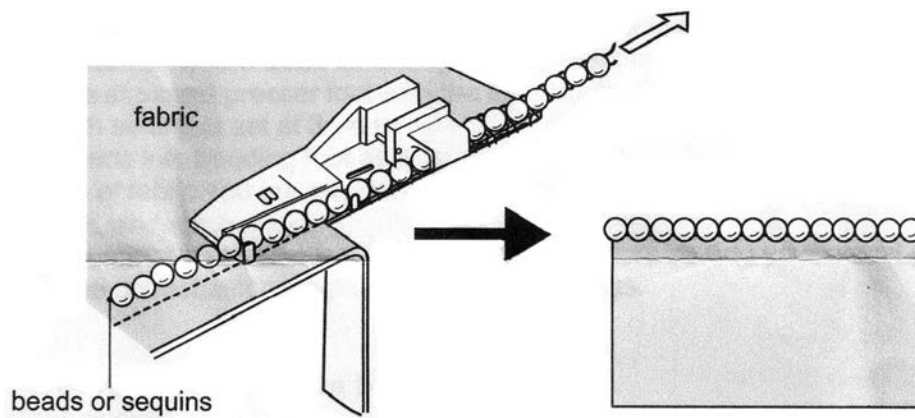

FOR THE LOVE OF SEWING

www.babylock.com

Belt Loop Binder

3/4 inch (19mm) (BLE8-S12)
1-1/2 inch (38mm) (BLE8-S11)

Instructions

Easily create straps, drawstrings, decorative trim, purse handles and of course, belt loops. This binder takes all of the work out of bias strips by folding and pressing them for you. Choose from 3/4" or 1-1/2" sizes.

MACHINE SETTINGS

Stitch type:	Triple Cover Stitch C1-C2-C3 Wide Cover Stitch C1-C3 (This is not a good application for chain or narrow cover stitches)
Sewing speed:	Moderate to slow
Fabrics used:	Lightweight woven fabrics cut on the bias
Stitch length:	3-4
Cutting blade:	Disengaged "LOCKED"
Upper looper:	Down
Sewing table:	On

Instructions:

1. Cut bias fabric strips:
3/4 inch Folder - Cut to 7/8 inch wide (22mm)
1-1/2 inch Folder - Cut to 1-5/8 inch wide (37mm)

Note: The strips must be cut this width even though it is wider than the attachment measurements.

2. Feed bias strip, with right side facing up, into the attachment.
3. Pull bias through and up to the needles and under the presser foot.
4. Turn the handwheel 3-4 times to secure the stitch in the fabric.



5. Align the attachment with the needle position to ensure the folded fabric is caught in the stitching. Make sure the stitch is centered in the belt looping.
6. Be sure to allow 3 inches of extra bias strip at the beginning and ending of project. The extra will be trimmed away when finishing the project.
7. It is best to test sew before attaching the bias to the project.

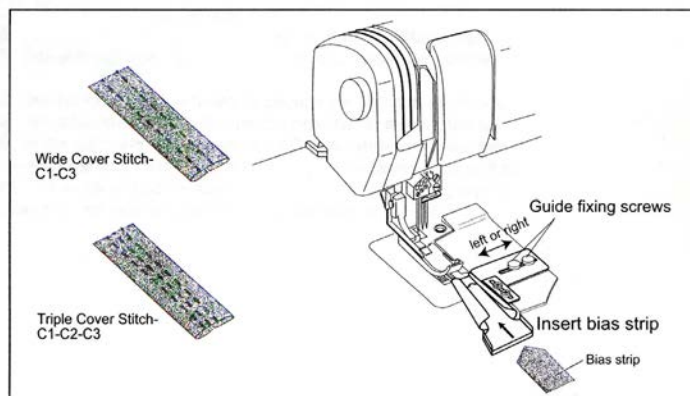

Note: When using BLCS-2 or BLCS the accessory adaptor BLCS-AA is needed.



FOR THE LOVE OF SEWING

www.babylock.com

Blindhem Foot

(BLE8-BLHF)

Instructions

Looking for a quick, easy way to make your hems invisible? This foot was designed specifically for easily stitching a blindhem on the serger. You can also use this foot for quick stitching along fabric edges.

MACHINE SETTINGS

Needle:	02
Upper knife:	Engaged "UNLOCKED"
Stitch type:	2-Thread Narrow Hem
Stitch selector:	B
Stitch width:	5.0 mm
Stitch length:	3.5
Differential feed:	N (N-0.6 for finer fabrics)

Instructions:

1. For hemming, fold fabric as shown in diagram.
2. Place garment with wrong side up under the presser foot. Before you begin serging, check the needle dropping position. The needle should just catch the fold of the fabric.
3. Once the needle dropping position has been determined, set the adjustable guide on the foot to the fold edge of the fabric. Move the adjustable guide by loosening the screw on top of the foot and adjusting the plate right or left. Then retighten the screw.

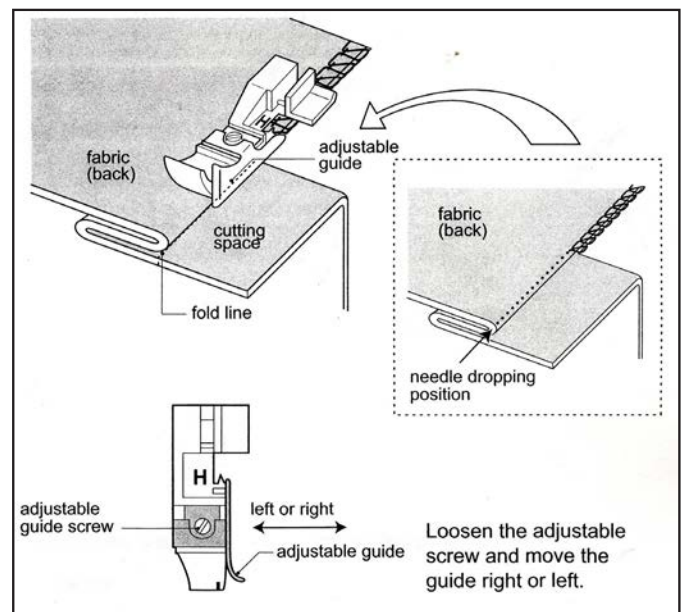

FOR THE LOVE OF SEWING

www.babylock.com

Clear Foot

(BLE8-CLF)

Instructions

Use this foot for better visibility when attaching ribbon and lace, or guiding lightweight decorative stitching. The raised guidelines on the foot ensure that you stitch with accuracy. This foot is perfect for decorative construction and the Baby Lock exclusive Wave Stitch.

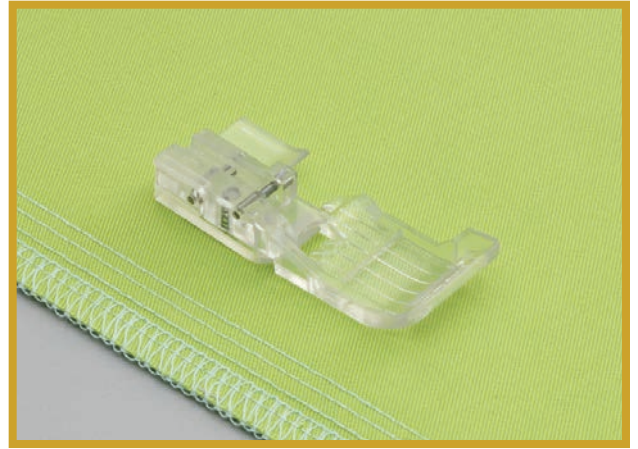

MACHINE SETTINGS

Any stitching application can be used (select one and check with instruction book for length and width setting for specific stitch selection).

1. Cut all threads to 4 inches (10 cm) in length.
2. Place fabric under the presser foot directly below the needles.
3. Lower the presser foot.
4. Turn the handwheel toward you to form 2 or 3 stitches.
5. Start to sew slowly.
6. After the first few stitches, stop and cut excess threads.
7. Start the next seam at the toe of the presser foot.

Note: You only need to raise and lower the presser foot when working with thick fabrics or when precise positioning is required.

Be careful not to push or pull the fabric. The serger will feed it evenly without help.

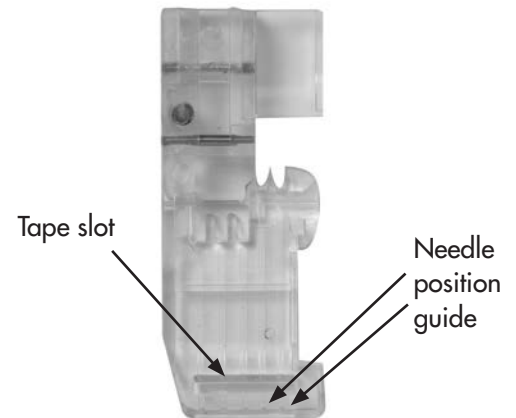

FOR THE LOVE OF SEWING

www.babylock.com

Cover/Chain Stitch Foot

(BLE8-CCF)

Instructions

Use the Cover/Chain Stitch foot for better visibility and easier control for stitching curves or turning tight corners and attaching tape and ribbons.

MACHINE SETTINGS:

Stitch: Left, right or center chain stitch, narrow, wide or triple cover stitch. (Select one and check with instruction book for length and width setting for specific stitch selection.)

Stitch Length: 3 to 4

Ribbon or tape: Up to 8mm wide

INSTRUCTIONS:

1. Snap on the Chain/Cover Stitch foot and set up the machine for the stitch you desire.
2. Raise the presser foot.
3. Place fabric under the foot.
4. If using the ribbon or tape slot in the front of the foot, insert ribbon into the slot and under the foot.

Note: The slot in the front of the foot is 7mm wide and will accommodate up to an 8mm wide ribbon or tape. Ribbons or tapes wider than 8mm are not recommended as they will not flow smoothly and will not lie flat when stitched.



5. Lower the presser foot.
6. Turn the handwheel toward you to form 2 or 3 stitches.
7. Start to sew slowly.
8. After the first few stitches, stop and cut excess threads.
9. Start the next seam at the toe of the presser foot.
10. Test sew sample for desired effect. Be careful not to push or pull the fabric. The serger will feed it evenly without help.

Note: This foot is not recommended for stitching over heavy or bulky areas such as seam allowances on mid-heavy weight polar fleece. It is recommended that seam allowances are clipped or trimmed to remove excess bulk before using this foot over such areas.



FOR THE LOVE OF SEWING

www.babylock.com

Curving Foot

(BLE8-CVF)

Instructions

The Curve Foot is short and has a flat sole, making it a good choice for stitching curves and sewing over cross seams. Its short size is also good for sewing around cuffs, necklines and children's wear using the cover stitches.

MACHINE SETTINGS:

Most stitching applications can be used (select one and check with instruction book for length and width setting for specific stitch selection). However, the Curving Foot does not work using the differential feed while serging since the foot does not contact the feed dogs completely. Also, this foot will not produce chain-off using the chain stitch.

TO RELEASE THE PRESSER FOOT:

1. Raise the presser foot lever.
2. Lower the cutting blade.
3. Raise the needles to the highest position.
4. Push the presser foot release lever located at the back of the presser foot holder.
5. Carefully turn the presser foot clockwise 90 degrees.
6. Slide the presser foot to the rear to remove.

TO REPLACE THE PRESSER FOOT:

1. Raise the presser foot lever.
2. Lower the cutting blade.
3. Raise the needles to the highest position.
4. Slide the foot from the left to right.
5. Align the bar of the foot with the groove in the holder.
6. Lower the presser foot lever to snap into place.

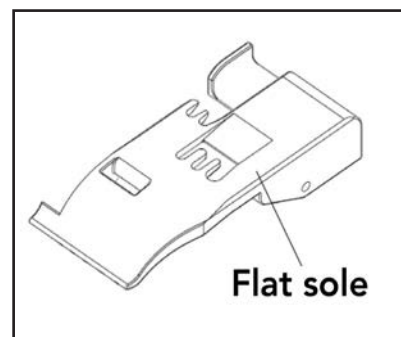
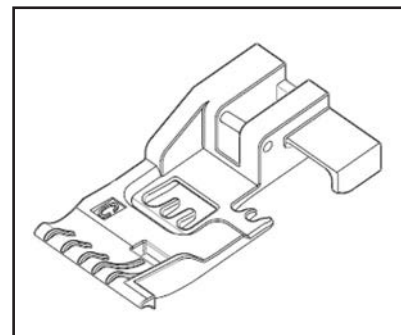
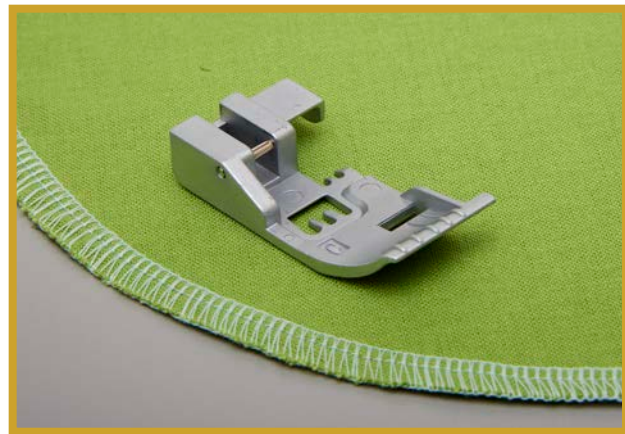

FOR THE LOVE OF SEWING

www.babylock.com

Double Fold Bias Binder

1-1/8 inch (28mm) (BLE8-S3)

1-1/2 inch (36mm) (BLE8-S2)

Instructions

This conventional binder will double fold and sew bias strips to your project in one quick step, using either a chain or coverstitch. Choose from two widths based on your preference.

MACHINE SETTINGS

Stitch type: 1-1/2"	Chain Stitch - C3 Needle Position C2-C3 Narrow Right Cover Stitch C2-C3
Stitch type: 1-1/8"	Narrow Right Cover Stitch Chain Stitch - C3 Needle
Stitch length:	3-4
Upper looper:	Down
Upper knife:	Disengaged "LOCKED"
Sewing table:	On

Bias Strip Cut Size:

1-1/8 inch Binder:

- Cut 1-1/8 inch bias from fine fabrics such as calico, muslin, etc.
- Cut 1 inch wide for medium weight fabrics such as trigger, lightweight denim.

1-1/2 inch Binder:

- Cut 1-3/8 inch for fine fabrics such as calico, muslin, etc.
- Cut 1-1/4 inch wide for medium weight fabrics such as trigger, lightweight denim.

Note: Test with fabric strip to make sure of correct width of bias.

Note: When using BLCS-2 or BLCS the accessory adaptor BLCS-AA is needed.



Instructions:

1. Secure attachment to table with guide fixing screws.
2. Cut fabric strips to size needed.
3. Raise presser foot. With the point of the bias strip, place strip into attachment. Use tweezers to feed the strip into the attachment.
4. Place the folded bias up to the needles and under the presser foot.
5. Turn the handwheel 3-4 times to secure the stitching in the fabric.
6. Place the fabric that is to be bound into the slot of the attachment. Place in the folded bias in front of the presser foot.
7. Loosen the guide fixing screws and move the attachment right or left to align the attachment with the needle position.
8. Sew test for proper alignment before sewing on project.

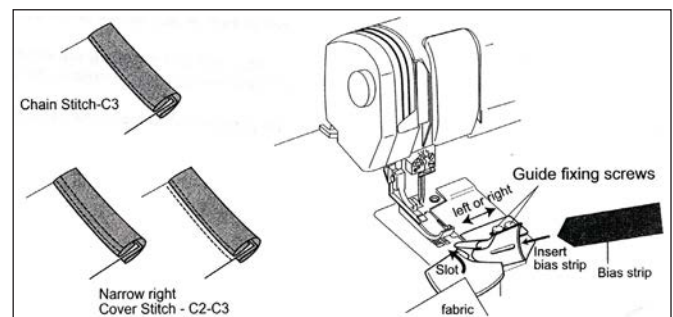

FOR THE LOVE OF SEWING

www.babylock.com

Elastic Foot

(BLE8-EF)

Instructions

Confidently serge elastic by letting this foot take care of all the work. This foot provides even pressure on the elastic every time to prevent pulling and tugging on the needles. The adjustable guide and tension dial allow you to serge elastic with a finished uniform stretch. The guide holes provide control for projects requiring fishing line.

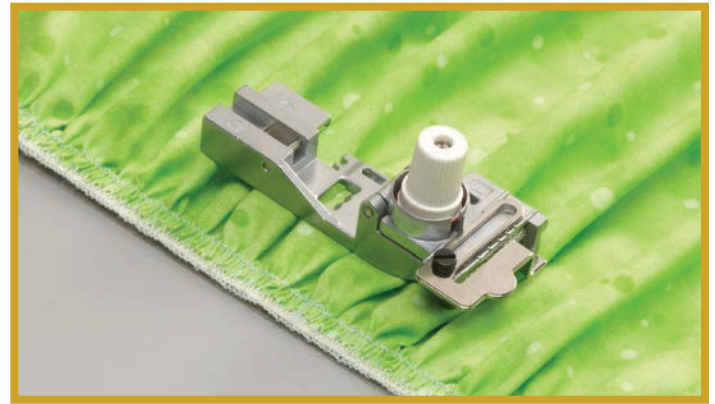

INSTRUCTIONS FOR ELASTIC FOOT:

1. Before attaching the elastic foot to the machine, loosen the elastic pressure adjustment screw, raise the pressure plate and insert the elastic until it reaches behind the foot (see illustration). Tighten the elastic pressure adjustment screw slightly.

Note: The lines on the screw are for elastic tension reference on future projects.

2. Replace the standard foot on the machine with the elastic foot and elastic.
3. While stitching elastic onto your test fabric, adjust the elastic pressure adjustment screw until the desired effect is achieved.

Note: To insert elastic while elastic foot is on machine, raise presser foot. Loosen elastic pressure adjustment screw, raise the pressure plate and insert elastic until it touches the needle. Stitch until the elastic passes the needle. Position fabric and then adjust pressure screw as needed.

ATTACHING ELASTIC USING THE ELASTIC FOOT:

MACHINE SETTINGS

Stitch type:	4-Thread Overlock
Needle:	01 and 02
Stitch width:	M-7.5
Stitch length:	4.0
Upper knife:	Engaged "UNLOCKED"
Differential feed:	0.5
Sewing speed:	Slow speed

1. Insert elastic into elastic foot (see instructions for elastic foot).
2. Set up machine according to above chart.
3. Slightly raise the pressure plate of the foot and insert elastic between the plate and lower support bar until the edge of elastic reaches the feed teeth. (It may be necessary to loosen the elastic pressure adjustment screw to feed the elastic through.)
4. Loosen the screw on the adjustable tape guide to accommodate the width of your elastic. Then re-tighten the screw.
5. Sew the elastic for about an inch or so to ensure it is feeding properly.
6. Place the fabric under the foot and sew elastic to fabric.
7. Adjust the elastic pressure adjustment screw so that the desired finish can be obtained.
 - a. Tighter tension on the elastic gives more elasticity of the fabric after it is sewn.
 - b. Looser tension on the elastic gives less elasticity of the fabric.

Parts description

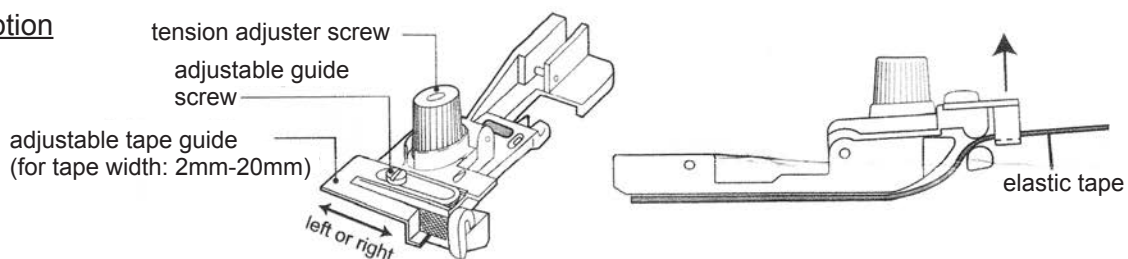

Elastic Foot

(BLE8-EF)

Instructions (continued)

COVERSTITCH:

MACHINE SETTINGS

Stitch type:	Triple Cover Stitch or Wide Cover Stitch
Needles:	Triple Cover Stitch-C1,C2,C3 Wide Cover Stitch-C1,C3
Stitch length:	4
Stitch width:	M
Differential feed:	Normal
Upper knife:	Disengaged "LOCKED"
Sewing table:	Remove knife cover and snap on sewing table
Sewing speed:	Slow

tension adjuster screw

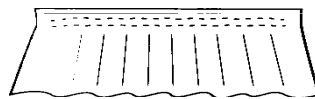
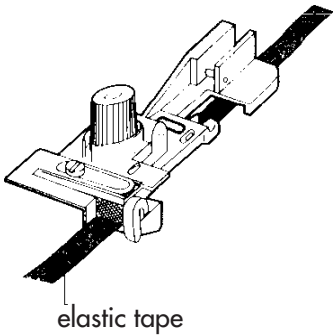

INSERTING FISHING LINE USING THE ELASTIC FOOT:

MACHINE SETTINGS

Stitch type:	3-Thread Rolled Hem
Needle:	02
Stitch selector:	D
Stitch width:	5.0
Stitch length:	1.5R (Rolled hem setting)
Differential feed:	0.6
Upper knife:	Engaged "Unlocked"
Sewing speed:	Slow

1. Thread your serger for a 3-thread rolled edge using decorative threads in the upper looper.
2. Slide the fishline through the guide holes on the right side of the elastic foot and then under the back of the foot leaving a 3" to 4" tail in the back.
3. Snap the foot on the machine and place the fabric under the foot with the fishline to the right of the needle.
4. Begin serging making sure the fishline is caught in the stitching as the edge is being rolled.
5. When you have finished serging, carefully remove the fabric and fishline from under the presser foot being careful not to pull the fishline out of the seam.

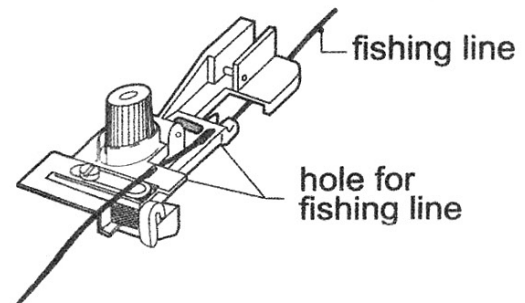

FOR THE LOVE OF SEWING

www.babylock.com

Fabric Guide

(BLES8-FG)

Instructions

If precise stitching lines are what you desire, attach the adjustable fabric guide to the table of your serger. The guide helps you align your fabric for perfect chain stitching every time.

MACHINE SETTINGS

Stitch type:	Chain Stitch or Cover Stitch
Needle:	C1, C2, C3
Cutting Blade:	Disengaged "LOCKED"
Upper Looper:	Down
Stitch width:	5.5
Stitch length:	1-4
Sewing table:	On

TO ATTACH TO MACHINE:

1. Thread the machine.
2. Turn the cutting blade to the "LOCKED" position.
3. Disengage the upper looper to the "DOWN" position.
4. Remove the blade cover and attach the sewing table.
5. Attach the fabric guide by securing the screws into the threaded holes in the sewing table.

TO ALIGN USE:

1. The raised markings on the toe of the foot indicate the needle positions to help guide your fabric for accurate stitching.
2. Align the "0" line of the fabric guide with the needle and the marking on the toe of the presser foot.



3. To use the Alignment template, drop the needle in the circle, then align the straight line with the marking lines on the toe of the foot and the "0" line on the fabric guide.

NOTE: Use actual size template for alignment purposes.

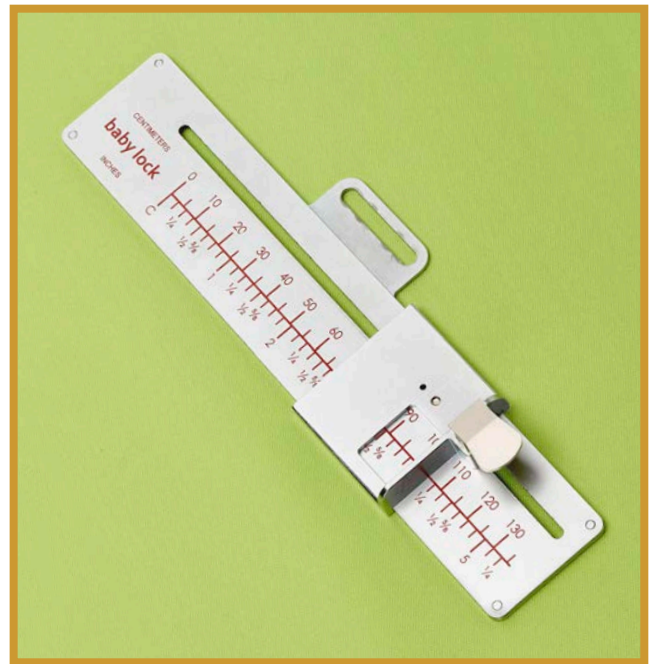

4. The numbers on the fabric guide indicate the distance from the needle to the edge of the fabric.
5. Position the fabric guide so that the distance from the needle to the raised edge of the fabric guide is the allowance you want to sew.
6. Secure the fabric guide to the sewing table.
7. Guide the edge of your fabric against the raised edge of the fabric guide.

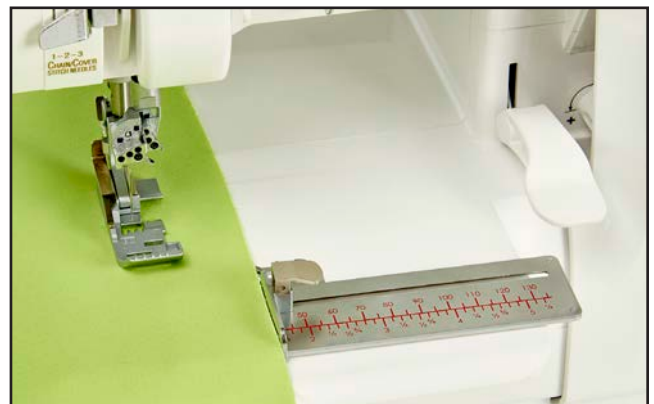

FOR THE LOVE OF SEWING

www.babylock.com

Knit/Woven Double Fold Bias Binder

8mm, 10mm, 15mm

(BLCS-DFBB8, BLCS-DFBB10, BLCS-DFBB15)

Instructions

This double fold bias binder will turn fabric strips into binding and attach it to project edges all in one step. Use this attachment with the Baby Lock Coverstitch machine, Baby Lock Triumph or the Baby Lock Ovation with the optional alternate table (BLES8-CST).

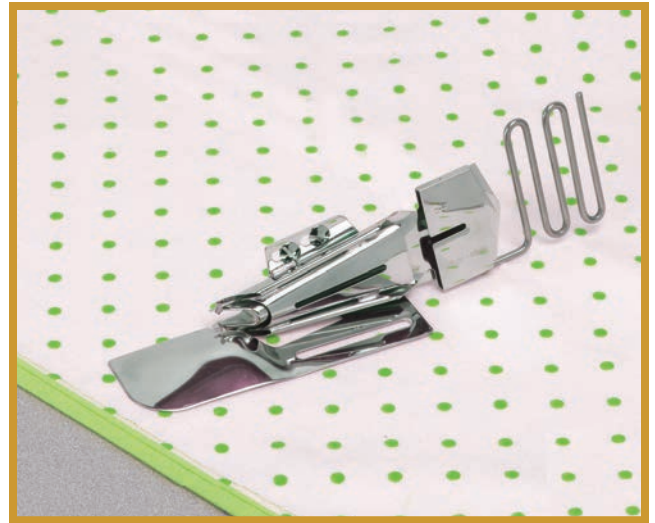

MACHINE SETTINGS

Stitch used:	Left, Center or Right Chain Stitch Narrow Left or Right Cover Stitch Wide Cover Stitch Triple Needle Cover Stitch
Sewing speed:	Moderate to Slow
Stitch length:	3-4

Application:

This double fold bias binder is a great attachment for binding your project edges with knit or woven fabrics.

Fabrics and Cutting Instructions:

- For binding strips on single knits, cut crosswise grain of fabric.
- For binding strips on woven fabrics, cut strips on the bias grain of fabric.
- For the 8mm binder - cut strips 30mm wide
- For the 10mm binder - cut strips 36mm wide
- For the 15mm binder - cut strips 48mm wide

Sewing Instructions:

1. With the wrong side of the fabric facing you, feed the binding strips through the serpentine fabric guide and into the binder.

Note: Cut the end of the strip at an angle to help feed it through the binder.

2. Lay the excess fabric strip to the right of the machine, making sure the strip is free of tangles.
3. Keep binding strip flat when feeding into attachment to ensure the fabric edges will roll under when sewing.
4. Pull binding strip out of the end of the binder and pivot the strip 90° to place it under the foot.
5. Make sure the binding strip is still folded when placing under the presser foot.
6. Feed the project to be bound along the left end of the attachment into the folded bias and under the presser foot.



FOR THE LOVE OF SEWING

www.babylock.com

Lace Applicator Foot

(BLE8-LF)

Instructions

Use this foot for guiding lace onto your fabric with a 2-thread flatlock or to attach ribbon to your fabric under a cover stitch. Or attach decorative trim by combining an overlock stitch with a chain stitch. Follow your "Quick Reference Threading Guide" for various stitches and settings.



MACHINE SETTINGS

Needle:	Right, left, both or Coverstitch
Upper knife:	Engaged "UNLOCKED"
Differential feed:	Normal
Stitch length:	3-4
Stitch width:	3.5

1. Snap on the lace applicator and set up the machine for the stitch you desire.
2. Loosen adjustable screw on the top of the lace foot (fig. 1).
3. Raise the presser foot.
4. Place fabric right side up under the foot up to the cutting blade.
5. Insert lace right side down into the guide and under the foot against the inside edge of the guide (fig. 2).
6. Align right edge of guide with placement of right edge of lace.
7. Move the guide right or left to align with the needles being used (fig. 3).
8. Lower the presser foot.
9. Check guide position and tighten the screw.
10. Test sew sample for desired effect.

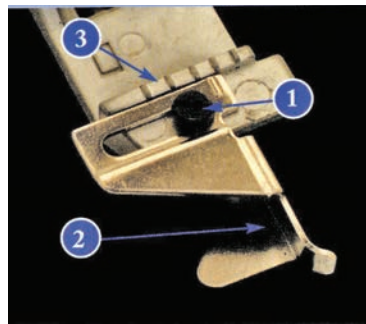

ADJUSTMENT OF GUIDE

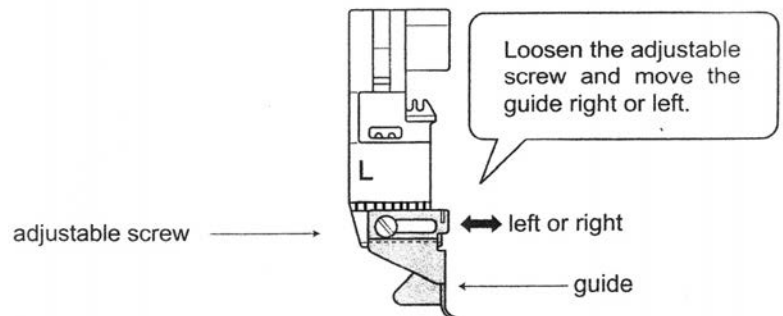

FOR THE LOVE OF SEWING

www.babylock.com

Open Toe Foot

(BLE8-OT)

Instructions

The wide opening in the front of this foot makes it perfect for projects that require extra visibility, such as aligning stitching lines on hems and decorative cover stitching.

MACHINE SETTINGS

Stitch type:	2, 3 or 4 thread stitches Single chain, double or triple needle coverstitch
Needles:	Overlock 1 or 2 Cover/chain 1, 2 or 3
Stitch width:	Any
Stitch length:	Any
Upper knife:	Engaged or disengaged
Differential feed:	0.6 to 2
Sewing Speed:	Normal

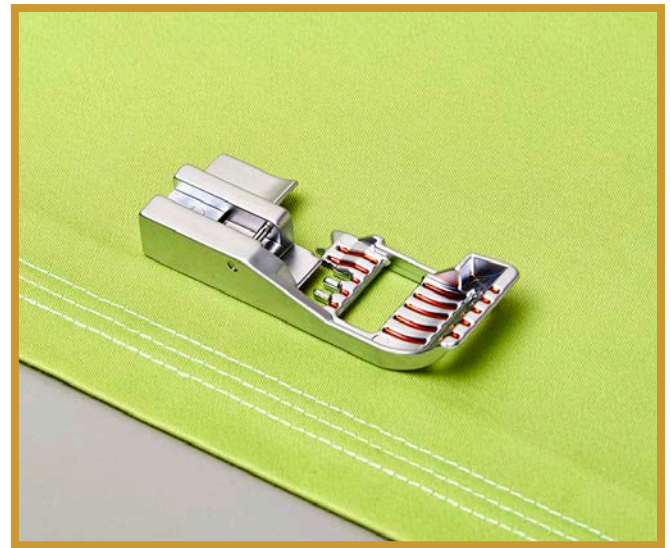

The red markings on the toe of the foot are seam line guides. They indicate the needle positions to help guide your fabric for accurate seaming.

To Release:

1. Raise the presser foot lever.
2. Lower the cutting blade.
3. Raise the needles to the highest position.
4. Push the presser foot release lever located at the back of the presser foot holder.
5. Carefully turn the presser foot clockwise 90 degrees.
6. Slide the presser foot to the rear to remove.

To Replace:

1. Raise the presser foot lever.
2. Lower the cutting blade.
3. Raise the needles to the highest position.
4. Slide the foot from the left to right.
5. Align the bar of the foot with the groove in the holder.
6. Lower the presser foot lever to snap into place.



FOR THE LOVE OF SEWING

www.babylock.com

Pintuck Foot

(BLE8-PTF)

Instructions

Use this foot on your serger to add beautiful texture to a classic heirloom or everyday garment. The groove on this foot allows for perfect spacing with professional results. Achieve precise pintucking when making corded and hollow tucks as well as parallel and curved forms.



1. Change to sewing table from knife cover.
2. Set needles C2 and C3.
3. Open the side cover, place one of the guides on the needle plate and close the side cover.
 - To make raised but non-corded pintucks, use guide A.
 - To insert cording into the pintuck, use guide B and slide the cord into the guide.
4. Place the fabric under the presser foot and sew it.

MACHINE SETTINGS

Needle:	C2 and C3
Upper knife:	Disengaged "LOCKED"
Stitch type:	Narrow Cover Stitch
Stitch width:	"M"
Stitch length:	3mm
Differential feed:	N (N-0.6 for finer fabrics)

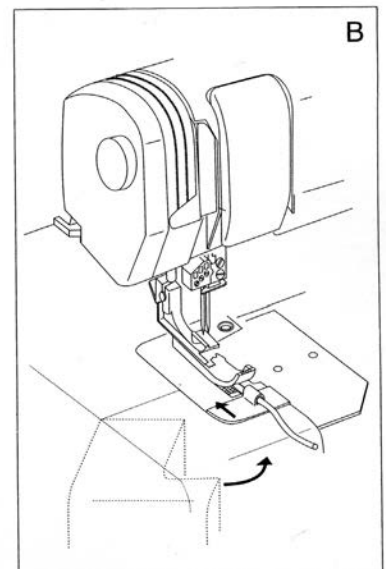
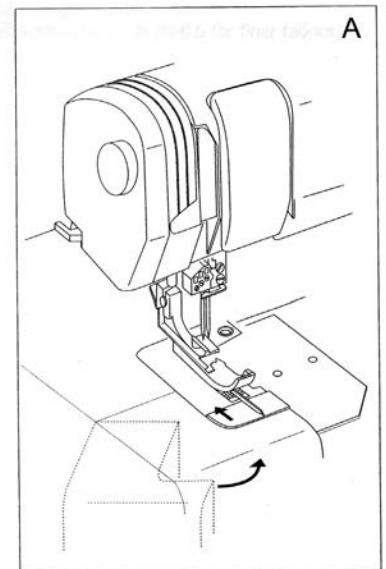

FOR THE LOVE OF SEWING

www.babylock.com

Piping/Cording Foot

5mm (BLE8-CF)

Instructions

Use this 5mm foot to create decorative stitching over cording on single and double layers of fabric. Attaching decorative cords and thread is a snap. This foot eliminates tangling to ensure that cords up to 5mm lie flat and perfectly parallel to each other. The cording foot controls threads so both hands can guide the fabric.

Piping in Seam

MACHINE SETTINGS

Stitch type:	4-Thread Overlock
Stitch selector:	A
Needle:	O1 and O2
Stitch width:	M -7.5
Stitch length:	3-3.5
Upper knife:	Engaged "UNLOCKED"
Differential feed:	N
Sewing speed:	Slow to moderate speed

To make covered piping:

Fold bias strip of fabric right side out around the cording and place the cording under the presser foot into the cord groove. Guide the raw edges of the folded bias along the right edge of the needle plate using the knife to trim excess fabric.

To cover and attach piping/cording in fabric seam:

1. Fold bias strip of fabric right side out around the cording.
2. Sandwich covered cording between 2 layers of fabric with right sides together.
3. Place under the presser foot with raw edges to the right and the cording in the cord groove in the sole of the foot.
4. Be sure to guide the cord in the groove while sewing.



Piping in Fabric Center

MACHINE SETTINGS

Stitch type:	2-Thread Chain Stitch
Needle:	C2 (5mm) or C3 (3mm)
Stitch width:	M
Stitch length:	3-3.5
Upper knife:	Disengaged "LOCKED"
Differential feed:	N
Sewing speed:	Slow to moderate speed

1. Fold fabric around cording with right side out.
2. Place cording under the presser foot into the cord groove.
3. Stitch C2 or C3 chain stitch, guiding the cord and fabric fold into the groove.

NOTE:

Try a 7-thread stitch for a completely different corded look. Use the C1 and C2 cover stitch settings combined with the 4-thread overlock settings. Place cording between 2 layers of fabric wrong sides together. The edge will finish with the 4-thread overlock while the left narrow cover stitch will sew on the left side of the cord.

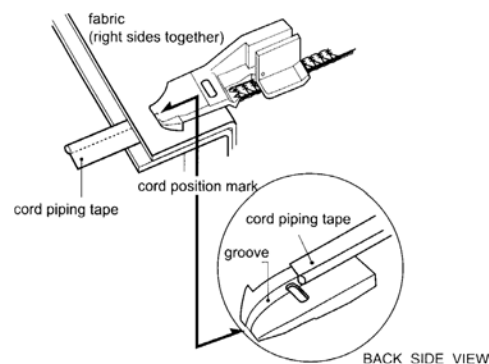

FOR THE LOVE OF SEWING

www.babylock.com

Plain Hemmer Foot

(BLE8-S6) 1/2 inch (13mm)

Instructions

Guide fabric into a perfectly straight hem without any pre-project pressing. The plain hemmer is designed to be used for straight hemming only. Leave one seam of the garment open. After hemming, sew the seam closed.



MACHINE SETTINGS

Stitch type:	Chain Stitch - C1 needle position Narrow Left Cover Stitch - C1 - C2 needle positions Wide Cover Stitch - C1 - C3 Triple Cover Stitch - C1 - C2 - C3
Stitch length:	3-4
Cutting blade:	Disengaged "LOCKED"
Differential feed:	N
Sewing speed:	Moderate to slow
Upper looper:	Down
Sewing table:	On

Fabrics:

Firm broadcloth, trigger, lightweight denim, lightweight polar fleece*, sweatshirt fleece*.

Note: When using BLCS the accessory adaptor BLCS-AA is needed.

Instructions:

1. Secure attachment to table with guide fixing screws.
2. Turn under 1/2 inch and press with iron.
3. Raise presser foot. Slide fabric into attachment with wrong side facing up, turning up and over to the left.
4. With a sewing awl, slide folded fabric under presser foot to the needle.
5. Lower the presser foot. Turn the handwheel 3-4 times to secure the fabric.
6. Align the attachment with the needle(s) to encase the fabric edge.
7. With right hand keep hem turned while left hand is guiding folded fabric into hemmer.

***NOTE:** When hemming lightweight polar fleece or sweatshirt fleece, turn fabric one time. Do not attempt a double roll. (Fabric does not ravel).

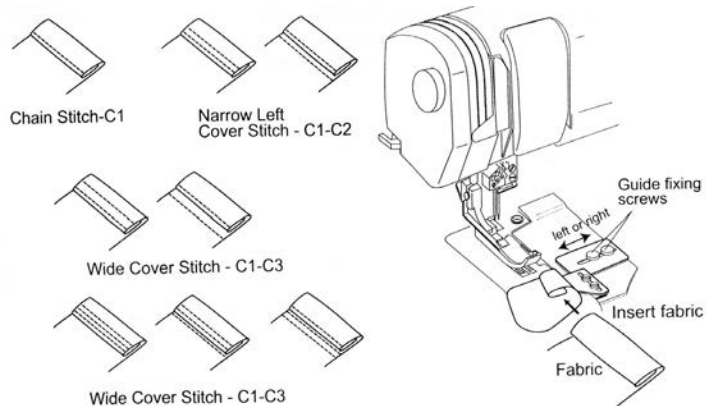

FOR THE LOVE OF SEWING

www.babylock.com

Plain Hemmer Foot

1/4 inch (6.5mm)

(BLE8-S7)

Instructions

Guide fabric into a perfectly straight hem without any pre-project pressing. The plain hemmer is designed to be used for straight hemming only. Leave one seam of the garment open. After hemming, sew the seam closed.

MACHINE SETTINGS

Stitch type:	Chain stitch
Stitch width:	M-7.5
Needle:	C2 needle position
Stitch length:	3-4
Upper knife:	Disengaged "LOCKED"
Differential feed:	N
Sewing speed:	Moderate to slow
Upper looper:	Down
Sewing table:	On

Fabrics:

Firm broadcloth, trigger, weaver's cloth, lightweight denim.
Not intended for use on polar fleece or sweatshirt fleece.

Note: When using BLCS-2 or BLCS the accessory adaptor BLCS-AA is needed.



Instructions:

1. Secure attachment to table with guide fixing screws.
2. Turn under 1/4 inch and press with iron.
3. Raise presser foot. Slide fabric into attachment with the wrong side facing up, turning up and over to the left.
4. With a sewing awl, slide folded fabric under presser foot to the needle.
5. Lower the presser foot. Turn the handwheel 3-4 times to secure the fabric.
6. Align the attachment with the needle to sew the fabric edge.
7. With right hand, keep hem turned while left hand is guiding folded fabric into the hemmer.

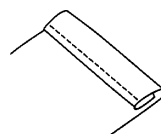

Chain Stitch-C2

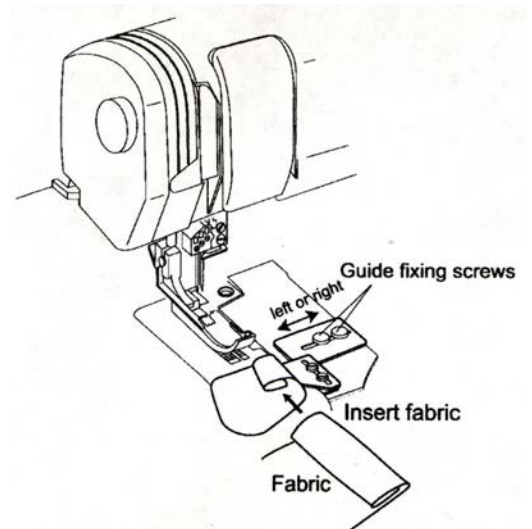

FOR THE LOVE OF SEWING

www.babylock.com

Quilt Guide

(BLES8-QG)

Instructions

The quilt guide is great for aligning exact rows of parallel cover or chain-stitching that are equally spaced.

INSTRUCTIONS:

1. Insert the stem of the quilt bar into the hole at the rear of the presser foot bar.

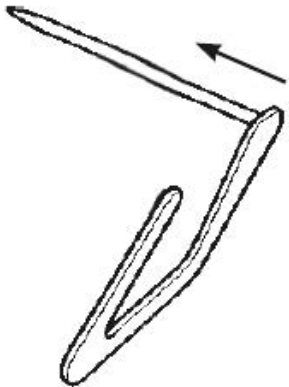

2. Adjust the stem of the quilt bar so that the guide aligns with the seam that has already been sewn.



3. Tighten the quilt bar fixing screw.

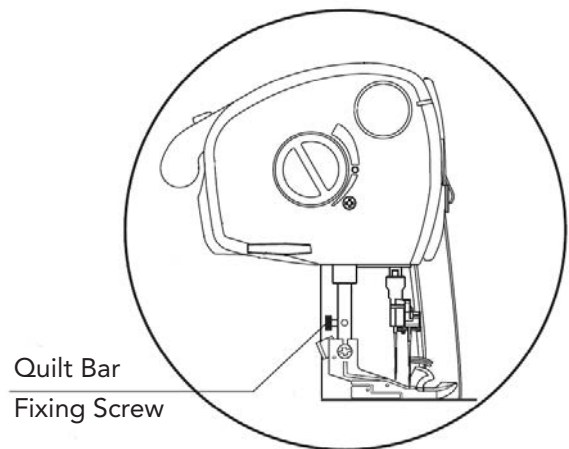

4. Continue to serge so the guide follows the previous row of stitching.



FOR THE LOVE OF SEWING

www.babylock.com

Ruffling Foot

(BLE8-RF)

Instructions

Easily make and attach ruffles as well as finish your edge in one simple step. Add perfectly spaced ruffles to garments, pillows, and other home décor items. This ruffling foot works on all fabric types.

MACHINE SETTINGS

Stitch type:	4-Thread Overlock
Stitch width:	M-7.5
Needle:	01 and 02
Stitch length:	4
Upper knife:	Engaged "UNLOCKED"
Differential feed:	2
Stitch selector:	A
Sewing speed:	Slow to moderate

GATHERING FABRIC:

Place one layer of fabric under the presser foot and sew. Generously feed fabric. The fabric will gather as you sew.

SHIRRING:

1. Place fabric to be gathered right side up under the presser foot and under the separator.
2. Position the fabric up to the needles. Turn handwheel forward 3-4 times to catch the fabric with the needles.
3. Place the fabric to attach the gather to right side down on top of the separator. (See illustration.) This keeps the fabric away from the feed dogs.
4. Place the fabric up to the needles. Turn the handwheel 3-4 turns to catch the fabric with the needles.
5. Gently guide the upper fabric into the separator while generously guiding the lower fabric that is being gathered under the separator. The ruffle will be sewn to the flat fabric while sewing.

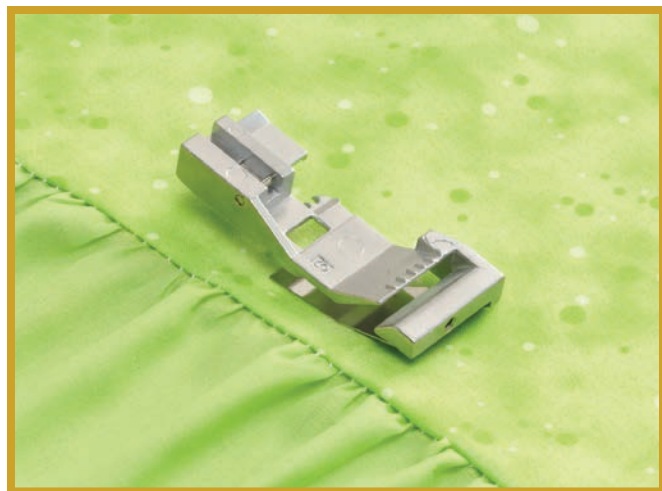

Note: Gathering works the best with fine fabrics. The heavier the fabric the less the gathering.

Fabric size

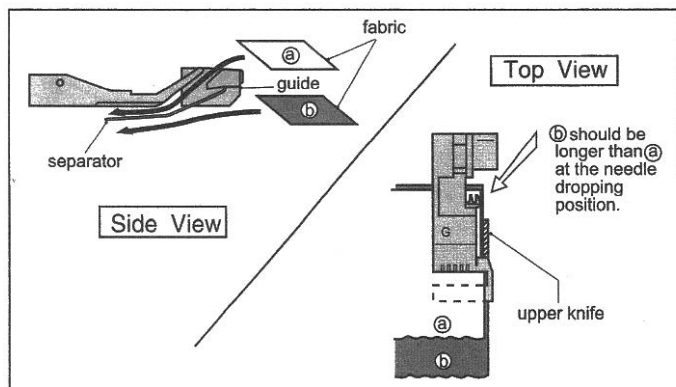

FOR THE LOVE OF SEWING

www.babylock.com

Single Downturn Feller

1/4 inch (6.5mm) (BLE8-S10)

5/8 inch (16mm) (BLE8-S8)

1 inch (25mm) (BLE8-S9)

Instructions

This single downturn feller turns the fabric downward into a perfectly straight single turn hem. You won't have to press your hems before using this feller, making downturn hems easy.

MACHINE SETTINGS

Stitch type: 1/4"	Narrow Left Cover Stitch-ONLY C1-C2
Stitch type: 5/8"	Narrow Left Cover Stitch-C1-C2 Wide Cover Stitch-C1-C3
Stitch type: 1"	Wide Cover Stitch-C1-C3 Triple Cover Stitch C1-C2-C3 Narrow Left Cover Stitch C1-C2
Sewing speed:	Moderate to slow
Stitch length:	3-4
Upper looper:	Down
Cutting blade:	Disengaged "LOCKED"
Sewing table:	On

Application: Hem straight edges of projects.

Fabrics: 1/4 inch Feller - lightweight denim, chambray, cotton broadcloth, calico, polyester, and rayon.

Note: Will not work with polar fleece or sweatshirt fleece.
5/8 inch & 1 inch Feller - lightweight denim, chambray, broadcloth, calico, ultrasuede, leather.

Note: Will work with two layers of lightweight polar fleece with no seams.

Note: When using BLCS-2 or BLCS the accessory adaptor BLCS-AA is needed.



Attachment Instructions: Make sure the attachment is in the front and the center screw positions of the mounting bracket to avoid being too close to the toe of the presser foot.

1. Secure the attachment to the table with guide fixing screws.
2. To start the hemming, finger press under 1/4 inch for 3-4 inches.
3. Feed the fabric (right side up) through attachment and pull the fabric to the needles and under the presser foot.
4. Make sure the fabric is still folded when placing under the presser foot.
5. Keep fabric turned under when feeding into the attachment to ensure the fabric will roll under when sewing.

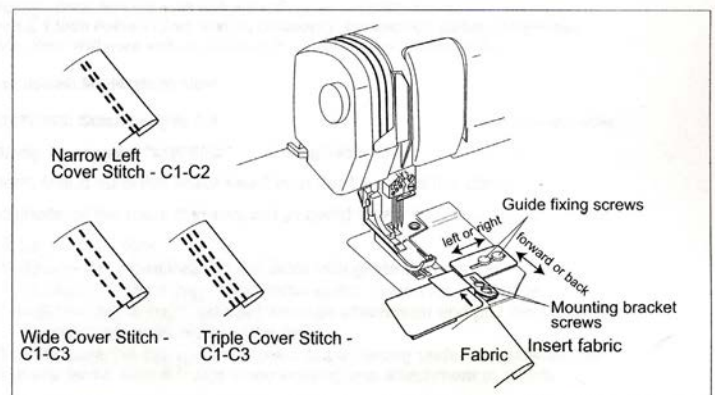

FOR THE LOVE OF SEWING

www.babylock.com

Single Fold Bias Binder

1-1/8 inch (28mm) (BLE8-S4)

1-5/8 inch (40mm) (BLE8-S5)

Instructions

This conventional binder will double fold and sew bias strips to your project in one quick step on the serger, using either a chain or cover stitch. Choose from two widths based on your preference.

MACHINE SETTINGS

Stitch type: 1-5/8"	Wide Cover Stitch C1-C3 Triple Cover Stitch C1-C2-C3
Stitch type: 1-1/8"	Wide Cover Stitch C1-C3
Stitch length:	3-4
Upper looper:	Down
Cutting blade:	Disengaged "LOCKED"
Sewing table:	On
Sewing speed:	Moderate to slow
Fabrics used:	Broadcloth, chambray, lace (width of bias strip), lightweight denim

Cutting width of bias strips:

1-1/8 inch (28mm) - cut bias strip 1-3/8 inch wide

1-5/8 inch (40mm) - cut bias strip 1-5/8 inch wide

Note: Heavier fabrics may need to be cut narrower.

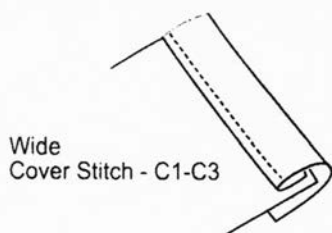

Instructions:

1. Secure attachment to table with guide fixing screws.
2. Feed bias strip into attachment with wrong side facing you.
3. With tweezers, pull the folded bias strip into the attachment, up to the needles and under the presser foot.
4. Turn the handwheel 3-4 times to secure the stitching in the fabric.
5. Make sure the alignment of the attachment is in place with the right needle position. The right needle must be sewing in the doubled fold on top of the fabric.
6. For proper attachment of bias to fabric, use wide or triple cover stitch.
7. When using triple cover stitch, the C3 needle thread is to be in the double fold edge and the C1 and C2 threads are to the left of the fold, sewing the raw edge down on the bottom of the fabric.
8. Sew test for proper alignment before sewing on project.

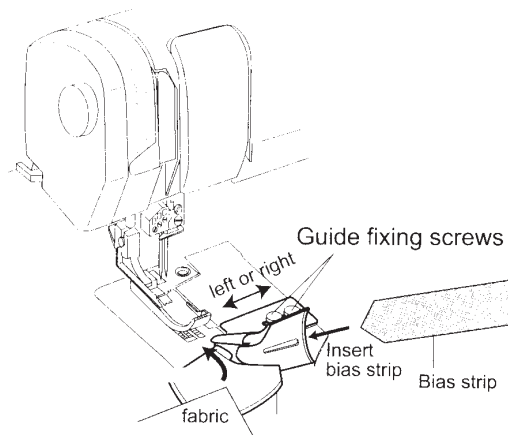

FOR THE LOVE OF SEWING

www.babylock.com

Single Fold Bias Binder Knit/Woven

15mm

(BLES8-SFB15)

Instructions

This Single Fold Bias Binder will turn fabric strips into binding and attach it to project edges all in one step. Use this attachment with the Baby Lock Coverstitch machine or the Baby Lock Ovation with the optional alternate table (BLES8-CST).

MACHINE SETTINGS

Stitch used:	Left, Center or Right Chain Stitch Narrow Left or Right Cover Stitch Wide Cover Stitch Triple Needle Cover Stitch
Sewing speed:	Moderate to Slow
Stitch length:	3-4

Application:

This Single Fold Bias Binder is a great attachment for binding your project edges with knit or woven fabrics.

Fabrics and Cutting Instructions:

- For binding strips on single knits, cut crosswise grain of fabric.
- For binding strips on woven fabrics, cut strips on the bias grain of fabric.
- For the 15mm binder - cut strips 40mm wide.

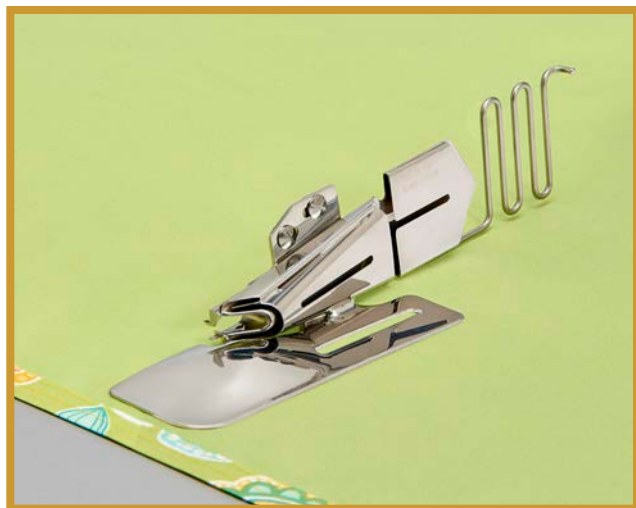

Edge Position:

1. Loosen screws A and B (Figure 1), set the fabric edge to the desired position (Figure 2).

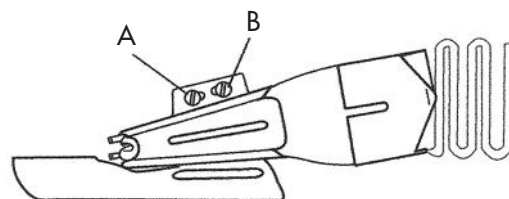

Figure 1

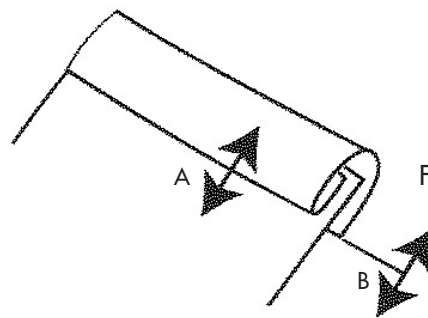

Figure 2



FOR THE LOVE OF SEWING

www.babylock.com

Single Fold Bias Binder Knit/Woven

15mm

(BLE8-EF)

Instructions (continued)

Sewing Instructions:

1. With the wrong side of the fabric facing you, feed the binding strips through the serpentine fabric guide and into the binder.

Note: Cut the end of the strip at an angle to help feed it through the binder.

2. Lay the excess fabric strip to the right of the machine, making sure the strip is free of tangles.
3. Keep binding strip flat when feeding into attachment to ensure the top fabric edge will roll under when sewing.
4. Pull binding strip out of the end of the binder and pivot the strip 90° to place it under the foot.
5. Make sure the binding strip is still folded when placing under the presser foot.
6. Feed the project to be bound along the left end of the attachment into the folded bias and under the presser foot.

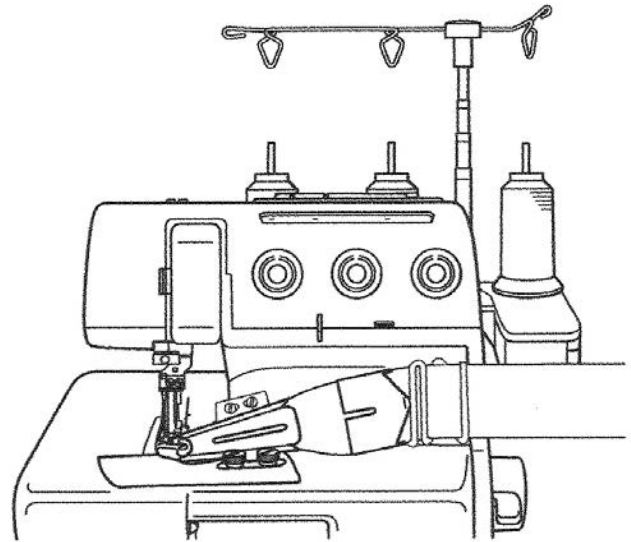

FOR THE LOVE OF SEWING

www.babylock.com

Teflon Flat Sole Foot

(BLE8-TF)

Instructions

This foot is perfect for sticky surfaces such as vinyl, and faux leathers. It also glides smoothly on heavy fabrics like denim and fleece or projects with multiple layers.

The Teflon flat sole foot moves smoother when it crosses over seams especially on fabrics like vinyl.

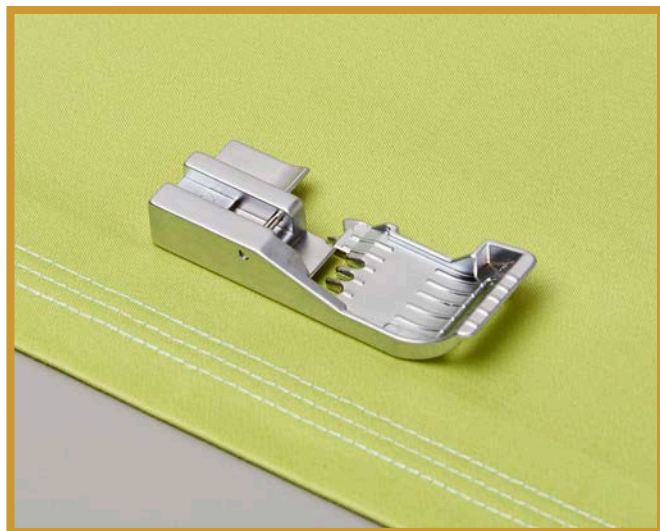

MACHINE SETTINGS

Needles:	Overlock 1 or 2 Cover/Chain 1, 2 or 3
Upper knife:	Engaged or disengaged
Stitch type:	2, 3 or 4 thread stitches Single chain, double or triple needle coverstitch
Stitch width:	Any
Stitch length:	Any
Differential feed:	0.6 to 2
Sewing Speed:	Normal

The raised markings on the toe of the foot are seam line guides. They indicate the needle positions to help guide your fabric for accurate seaming.

The presser foot also has a tape sewing slot in the front of the foot. Insert the tape or ribbon, into the slot, then under the sole of the foot.

To Release:

1. Raise the presser foot lever.
2. Lower the cutting blade.
3. Raise the needles to the highest position.
4. Push the presser foot release lever located at the back of the presser foot.
5. Carefully turn the presser foot clockwise 90 degrees.
6. Slide the presser foot to the rear to remove.

To Replace:

1. Raise the presser foot lever.
2. Lower the cutting blade.
3. Raise the needles to the highest position.
4. Slide the foot from the left to right.
5. Align the bar of the foot with the groove in the holder.
6. Lower the presser foot lever to snap into place.



FOR THE LOVE OF SEWING

www.babylock.com



FOR THE LOVE OF SEWING

www.babylock.com